

# 600 LB. CAST STAINLESS STEEL THREADED & SOCKET WELD "Y" STRAINERS

## MODELS: S9-600 & S6-600

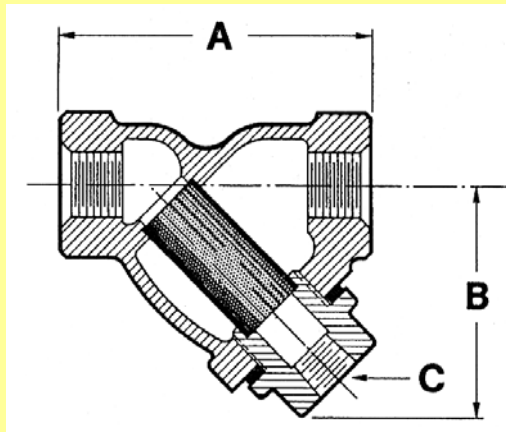

S9-600

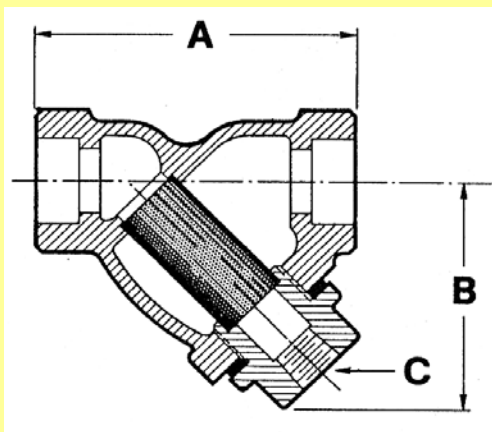

S6-600

DIMENSIONS & WEIGHTS APPROXIMATE  
(Apply for certified drawings)

SIZE in.	1/4"	3/8"	1/2"	3/4"	1"	1 1/4"	1 1/2"	2"
mm	8	10	15	20	25	32	40	50
A	2 15/16	2 15/16	2 15/16	3 11/16	4 9/16	4 15/16	5 9/16	6 15/16
B	2 3/8	2 3/8	2 3/8	2 13/16	3 1/8	4	4 3/4	6
C (NPT)	1/4	1/4	1/4	3/8	3/8	3/4	3/4	1
WT (lb.)	2	2	2	3	5	6.8	9.8	15
Cv (gpm)	9	9	9	18	28	42	60	92

PRESSURE-TEMPERATURE RATINGS	
STEAM:	845 psi @ 750° F
WOG:	1440 psi @ 100° F

### SERVICE RECOMMENDATIONS

These Fabrotech strainers are designed for long term use under high pressure and temperature conditions. They are perfectly suited for corrosive applications and will provide excellent protection to expensive mechanical equipment such as pumps and valves. Self cleaning is readily accomplished by opening the plug or valve connected to the blow-off outlet.

### FEATURES

The S9-600 & S6-600 contain cast stainless steel straight threaded caps, with an NPT blowoff connection as a standard. Blind caps are available and should be specified when ordering. Fabrotech can supply pipe plugs for the blowoff. The body and cap have machined seats which ensure proper screen alignment and reseating.

### SCREENS

304 stainless steel screens are normally furnished in the following perforations:

Steam Service: .033"  
Liquid Service: .062"

Other materials, such as Monel, Hastelloy-C, & Alloy-20 are available. Other perforation sizes and/or mesh lining is also available. Contact Fabrotech for pricing.

### CONSTRUCTION

The body, which is cast from Stainless Steel (ASTM A351, Gr. CF8M), is available from stock. Normally furnished with extra heavy bore, but also available to correspond to the inside diameter of standard pipe. The gasket is stainless steel spiral wound graphite filled, and is limited to 750° F.

### INDIVIDUALLY HYDROSTATICALLY TESTED

## FABROTECH INDUSTRIES, INC.

2089 NINTH AVENUE, RONKONKOMA, NEW YORK 11779

TEL: (631) 467-2040 FAX: (631) 467-2196 e-mail: info@fabrotech.com

www.fabrotech.com