

900 LB. CAST STAINLESS STEEL FLANGED & BUTTWELD "Y" STRAINERS

MODELS: S8-900 & S7-900

PRESSURE-TEMPERATURE RATINGS (B16.5)	
STEAM	900 psi @ 838° F
WOG	2,160 psi @ 100° F

SERVICE RECOMMENDATIONS

Fabrotech's S8-900 and S7-900 are designed for long term use in high pressure and corrosive applications. They offer complete protection to mechanical equipment such as pumps & valves at high temperatures & pressures.

FEATURES

All sizes feature a bolted cover machined to receive the screen. Both models (flanged and butt weld) are furnished with stainless steel graphite filled cover gaskets which are designed for high temperature service. Covers are normally furnished blind but socket weld or NPT blowoff connections are available. Specify when ordering.

SCREENS

Fabrotech supplies heavy gauge 304 SS screens which are normally furnished in the following perforations:

SERVICE:	1/2" - 4"	5" to 8"
Steam:	.033"	.045"
Liquid :	.062"	1/8"

Other materials, such as Monel, Hastelloy-C, & Alloy-20 are available. Other perforation sizes and/or mesh lining is also available.

CONSTRUCTION

Extremely rugged bodies available from stock in Stainless Steel ASTM A351 Gr. CF8M. Chrome Moly bolting is standard for all sizes. All models have machined seats in the body & cover to ensure accurate screen alignment. Flanged models have end flanges faced and drilled in accordance with ANSI B16.5. Ring type joint end flanges are available. For S7-900, specify bore schedule of mating pipe for proper machining.

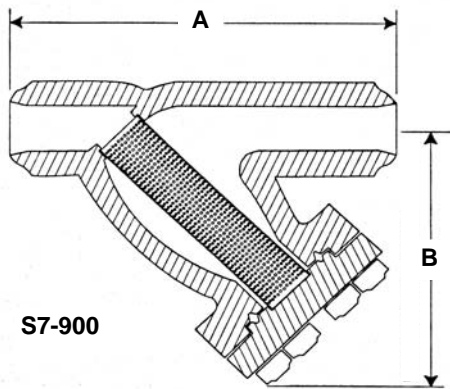
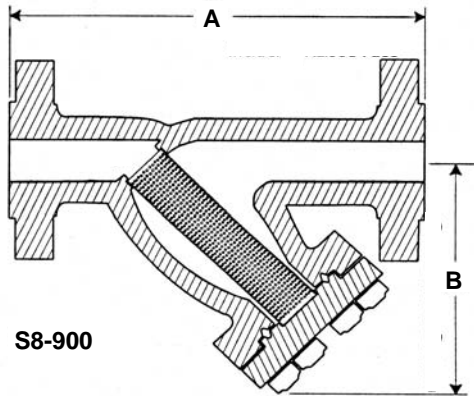

DIMENSIONS & WEIGHTS APPROXIMATE
(Apply for certified drawings)

INDIVIDUALLY HYDROSTATICALLY TESTED

SIZE	in. mm	1/2" 15	3/4" 20	1" 25	1 1/4" 32	1 1/2" 40	2" 50	3" 80	4" 100	6" 150	8" 200
A	S8-900	8 1/8	9 1/16	10 3/4	12	12	13 15/16	17 1/2	23 1/4	27 3/4	33 1/4
	S7-900	7 3/8	8 3/16	9 11/16	12	12	13 15/16	17 1/2	23 3/8	27 7/8	33 3/8
B	S8-900	4 1/4	4 3/4	5 3/4	6 3/4	6 3/4	7 1/2	10 3/4	15	18 7/8	23 7/8
	S7-900	4 1/4	4 3/4	5 3/4	6 3/4	6 3/4	7 1/2	10 3/4	15	18 7/8	23 7/8
WT (lb)	S8-900	20	30	52	64 1/2	64 1/2	93	185	250	560	1000
	S7-900	10	17	25	29	36	44 1/2	100	266	430	780
Clean Cv (gpm)		30	35	40	40	40	70	150	250	550	900

FABROTECH INDUSTRIES, INC.

2089 NINTH AVENUE, RONKONKOMA, NEW YORK 11779

TEL: (631) 467-2040 FAX: (631) 467-2196 e-mail: info@fabrotech.com

www.fabrotech.com