

300# CAST 316 STAINLESS STEEL FLANGED & BUTTWELD "Y" STRAINERS

MODELS: S8-300 & S7-300

PRESSURE-TEMPERATURE RATINGS	
STEAM:	300 psi @ 1125° F
WOG:	720 psi @ 100° F

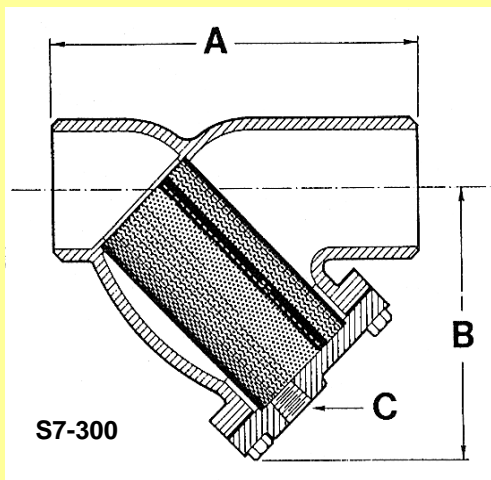
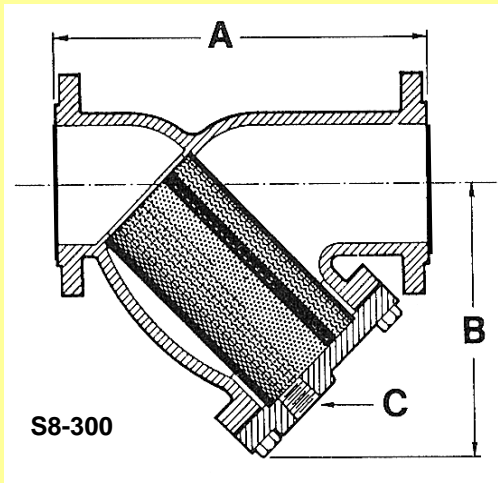

DIMENSIONS & WEIGHTS APPROXIMATE
(Apply for certified drawings)

SERVICE RECOMMENDATIONS

These strainers are designed for dependable service under demanding conditions. They offer complete protection to mechanical equipment such as pumps & valves under corrosive conditions & high pressures. Self cleaning is accomplished by opening the plug or valve connected to the blow-off outlet (not supplied).

FEATURES

All sizes feature a bolted cover machined to receive the screen. Cover gaskets are stainless steel spiral wound. Studs are ASTM A193 B7 and the nuts are ASTM A194-2H heavy hex. Covers are supplied with a blowoff tapping, but without a plug.

SCREENS

Fabrotech supplies sturdy 304 SS screens which are normally furnished in the following perforations:

SERVICE:	1/2" - 4"	5" to 14"
Steam:	.033"	.045"
Liquid :	.062"	1/8"

Other materials, such as Monel, Hastelloy C, & Alloy-20 are available. Other perforation sizes and/or mesh lining is also available.

CONSTRUCTION

Typically, the body is constructed of Stainless Steel ASTM A351 Gr. CF8M. Both models are available in Alloy 20, Monel & Hastelloy C castings. The bodies of both the S8-300 & S7-300 are designed to meet 300 lb. ANSI specifications. Model S8-300 has RF flanges and model S7-300 ends are machined to match standard weight pipe. All models have machined seats in the body & cover to ensure accurate screen alignment. Each unit is individually hydrostatically tested.

SIZE	in.	1/2"	3/4"	1"	1 1/4"	1 1/2"	2"	2 1/2"	3"	4"	5"	6"	8"	10"	12"	14"
	mm	15	20	25	32	40	50	65	80	100	125	150	200	250	300	350
A	S8-300	6 1/8	7 3/4	7 7/8	7 1/2	7 5/8	8 5/8	10 5/8	12	14 1/2	16 3/8	20	23 3/8	27 3/8	32	35
	S7-300	6 5/8	8 5/16	8 5/16	10 1/8	10 1/4	8 5/8	10 5/8	12	14 1/2	16 3/8	20	23 3/8	27 3/8	32	35
B	S8-300	3 1/2	3 3/4	3 3/4	4 3/4	4 3/4	5 1/4	6 1/2	7	8 1/4	11 1/4	13 1/2	15 3/4	19	22 1/4	25
	S7-300	3 1/2	3 3/4	3 3/4	5 1/4	5 1/4	5 1/4	6 1/2	7	8 1/4	11 1/4	13 1/2	15 3/4	19	22 1/4	25
C	NPT	3/8	1/2	1/2	1/2	1/2	1/2	1	1	1 1/2	2	2	2	2	2	2
WT (lb)	C8-300	5 1/2	12 1/4	13	18 1/4	18	22	32	49	90	120	175	300	440	650	1075
	C7-300	3	9	9	12	13	10	14	20	40	60	90	168	250	440	765
Clean Cv (gpm)		30	35	40	40	40	70	100	150	250	390	550	900	1500	2200	3100

Also available in sizes 16" thru 24"

FABROTECH INDUSTRIES, INC.

2089 NINTH AVENUE, RONKONKOMA, NEW YORK 11779

TEL: (631) 467-2040 FAX: (631) 467-2196 e-mail: info@fabrotech.com

www.fabrotech.com