

900 LB. CAST CARBON STEEL FLANGED & BUTTWELD "Y" STRAINERS

MODELS: C8-900 & C7-900

PRESSURE-TEMPERATURE RATINGS (B16.5)

STEAM	900 psi @ 838° F
WOG	2,220 psi @ 100° F

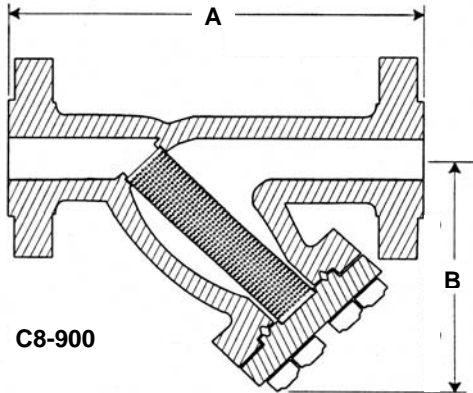

SERVICE RECOMMENDATIONS

The C8-900 and C7-900 strainers are designed for dependable service under high pressure conditions. They offer complete protection to mechanical equipment such as pumps & valves at high temperatures & pressures.

FEATURES

All sizes feature a bolted cover machined to receive the screen. Fabrotech's C8-900 and C7-900 are supplied with stainless steel spiral wound, graphite filled cover gaskets which are designed for high temperature service. Covers are normally furnished blind but socket weld or NPT blowoff connections are available. Please specify at time of order.

SCREENS

Fabrotech supplies heavy gauge 304 SS screens which are normally furnished in the following perforations:

SERVICE:	1/2" - 4"	5" to 8"
Steam:	.033"	.045"
Liquid :	.062"	1/8"

Other materials, such as Monel, Hastelloy C, & Alloy-20 are available. Other perforation sizes and/or mesh lining is also available.

CONSTRUCTION

Extremely rugged and thick wall bodies are cast in Carbon Steel ASTM A216 Gr. WCB. Both models are available in Chrome Moly (ASTM A217 Gr. WC6 & WC9). The standard cover is HRS plate. All models have machined seats in the body & cover to ensure accurate screen alignment. Flanged models have end flanges faced and drilled in accordance with ANSI B16.5. Ring type joints are available. Buttweld ends in accordance with ANSI B16.25 Fig. 2(B). For C7-900, specify bore schedule of mating pipe for proper machining. Chrome Moly studs and heavy hex nuts are standard.

DIMENSIONS & WEIGHTS APPROXIMATE

(Apply for certified drawings)

INDIVIDUALLY HYDROSTATICALLY TESTED

SIZE in.		1/2"	3/4"	1"	1 1/4"	1 1/2"	2"	2 1/2"	3"	4"	6"	8"
mm		15	20	25	32	40	50	65	80	100	150	200
A	C8-900	8 1/8	9 1/16	10 3/4	12	12	13 15/16	17 3/8	17 1/2	23 1/4	27 3/4	33 1/4
	C7-900	7 3/8	8 3/16	9 11/16	12	12	13 15/16	17 3/8	17 1/2	23 3/8	27 7/8	33 3/8
B	C8-900	4 1/4	4 3/4	5 3/4	6 3/4	6 3/4	7 1/2	10 3/4	10 3/4	15	18 7/8	23 7/8
	C7-900	4 1/4	4 3/4	5 3/4	6 3/4	6 3/4	5 1/4	10 3/4	10 3/4	15	20	26 15/16
WT (lb)	C8-900	20	30	52	64 1/2	64 1/2	93	185	185	250	560	1000
	C7-900	10	17	25	29	29	44 1/2	100	100	266	430	780
Clean Cv (gpm)		30	35	40	40	40	70	100	150	250	550	900

FABROTECH INDUSTRIES, INC.

2089 NINTH AVENUE, RONKONKOMA, NEW YORK 11779

TEL: (631) 467-2040 FAX: (631) 467-2196 e-mail: info@fabrotech.com

www.fabrotech.com