

CLASS 125 / 150 SIMPLEX FLANGED BASKET STRAINER

MODELS:

- 125F:** Cast Iron (ASTM A126-B)
- 125F-B:** Bronze (ASTM B62, Type 85-5-5-5)
- 125F-CS:** Carbon Steel (ASTM A216, Gr. WCB)
- 125F-SS:** Stainless Steel (ASTM A351, Gr. CF8M)

WOG PRESSURE-TEMPERATURE RATINGS <i>(Note: the 125F series is not recommended for steam)</i>	
125F: Cast Iron	200 psi @ 150°F
125FB: Bronze	225 psi @ 150°F
125FCS: Carbon Steel	285 psi @ 100°F
125FSS: Stainless Steel	275 psi @ 100°F

SERVICE RECOMMENDATIONS

These strainers are used to remove foreign matter from pipe lines and provide inexpensive protection to pumps, meters, valves, etc. In appropriate material, the 125F series can be specified for drinking water, cooling water, sea water, etc.

FEATURES

These strainers have been designed for applications where easy maintenance & large capacity straining are needed. Service time is minimal because the cover is secured with quick opening, non-yoke type knobs. Both the cover & the basket use O-ring seals, eliminating the need to replace gaskets each time the strainer is serviced. This, combined with the machined basket seat eliminates particle bypass. With the appropriate wire mesh lining, these models can be used to strain particles as small as five microns.

CONSTRUCTION

Cast cover and body. All sizes feature an O-ring cover seal. Baskets and O-ring are sealed in machined seats. Quick release knobs are insert molded with metal threads. A plugged NPT connection is provided ("D"). Coatings are available on application. Standard basket is .062 perf 304 ss for sizes 1" thru 4". Sizes 5" and larger have 1/8" perf 304ss baskets. Buna-N O-ring is standard for all models except stainless steel, which is supplied with a Viton O-ring. Floor supports with bolting holes are provided on sizes 4" & larger.

CAPACITY: Minimum 6 to 1 open area ratio.

DIMENSIONS & WEIGHTS ARE APPROXIMATE
(Apply for certified drawings)

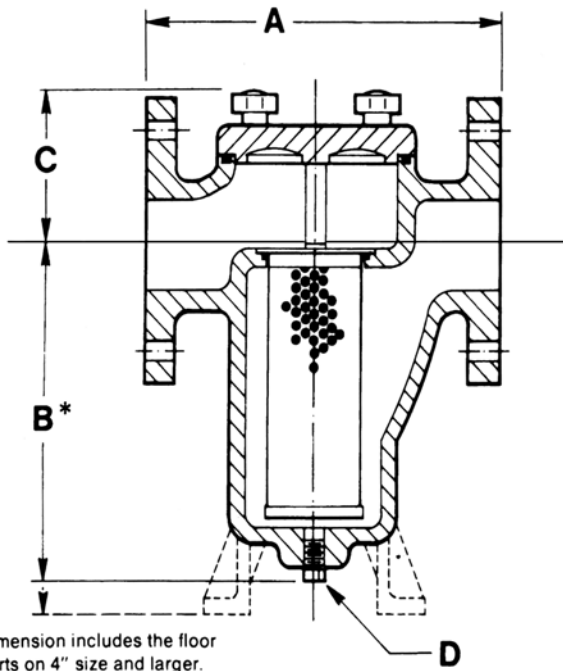

SIZE in.	1"	1 1/4"	1 1/2"	2"	2 1/2"	3"	4"	5"	6"	8"
mm	25	32	40	50	65	80	100	125	150	200
A	5 11/16	6 15/16	6 15/16	9	10 3/8	11 3/4	15	18 3/8	20 1/4	27 3/8
B	4 11/16	6 1/2	6 1/2	7 7/8	8 3/4	11 3/8	15 7/8	18 3/8	22 3/8	27 3/4
C	2 3/4	3	3	3 5/8	4	4 1/2	5 3/4	7 7/16	8 3/16	9 3/16
D (npt)	3/8	1/2	1/2	3/4	1	1	2	2	2	2
WEIGHTS (lb.)										
Cast Iron	9	15	15	26	38	62	118	170	266	518
Bronze	11	18	18	31	45	72	147	210	315	553
Carbon/Stainless	10	16	16	25	41	65	135	190	270	497

FABROTECH INDUSTRIES, INC.

2089 NINTH AVENUE, RONKONKOMA, NEW YORK 11779

TEL: (631) 467-2040 FAX: (631) 467-2196 e-mail: fabrotec@aol.com

www.fabrotech.com